

STUDENTS' SPACE ASSOCIATION  
THE FACULTY OF POWER AND AERONAUTICAL ENGINEERING  
WARSAW UNIVERSITY OF TECHNOLOGY



## PRELIMINARY DESIGN REVIEW



---

### CAMERAS

Phase B of PW-Sat2 student satellite project

June 2015

Issue 2 (November 2016 update)

	PW-Sat2	Preliminary Design Review	
	2016-11-29	Cameras	
	Phase B		

## Changes

Date	Changes	Responsible
2015-02-23	Initial issue	Mateusz Sobiecki
2015-05-29	Editorial changes	Dominik Roszkowski
2015-08-11	Small editorial changes	Dominik Roszkowski
2016-11-29	New template, disclaimer	Dominik Roszkowski

**Attention** Phase B documentation may be outdated in many points. Please be aware of that and do not depend on Phase B or Phase A documents only. More recent documentation is available on project website.

---

Published by

Students' Space Association

Warsaw University of Technology, 2015



This work is licensed on CC BY-NC 3.0

Project logo by Krzysztof Karaś

Artist's impressions by Marcin Świetlik



Quote as: PW-Sat2 Team, *Phase B Documentation – Preliminary Design Review – Cameras (Issue 2)*, Students' Space Association, Warsaw University of Technology, pw-sat.pl 2015

---

	PW-Sat2	Preliminary Design Review	
	2016-11-29	Cameras	
	Phase B		

## Table of contents

<b>1</b>	<b>Introduction</b>	<b>5</b>
1.1	Purpose and scope .....	5
<b>2</b>	<b>References</b>	<b>6</b>
2.1	Project documents .....	6
2.2	Reference Documents .....	6
<b>3</b>	<b>Cameras objectives</b>	<b>7</b>
3.1	Team Objectives .....	7
3.2	General requirements .....	7
<b>4</b>	<b>CAM1 design</b>	<b>8</b>
4.1	CAM1 properties .....	8
4.2	Mechanical design.....	9
4.3	CAM1 on-orbit operation.....	10
<b>5</b>	<b>CAM2 design</b>	<b>11</b>
5.1	CAM2 properties .....	11
5.2	CAM2 mechanical design .....	12
5.3	CAM2 on-orbit operation.....	13
<b>6</b>	<b>Conclusions and future work</b>	<b>14</b>

	PW-Sat2	Preliminary Design Review	
	2016-11-29	Cameras	
	Phase B		

**List of figures**

Figure 4-1 CAM1 and mounting elements ..... 9

Figure 4-2 CAM1 position on the satellite ..... 10

Figure 5-1 CAM2 field of view: 65° (blue), 95° (yellow) ..... 12

Figure 5-2 CAM2 mounting ..... 13

**List of tables**



Table 2-1 List of applicable project documents..... 6

Table 2-2 List of applicable reference documents ..... 6

Table 4-1 CMOS sensor parameters..... 8

Table 4-2 Selected lens parameters ..... 8

Table 5-1 CMOS module parameters ..... 11

	PW-Sat2	Preliminary Design Review	
	2016-11-29	Cameras	
	Phase B		

### Abbreviated terms

ADCS – Attitude Determination and Control System

COMM – Communication subsystem

DT – Deployment Team (mechanical team, responsible for sail system and solar arrays opening mechanism)

EPS – Electrical Power System

ESA – European Space Agency

ESEO – European Students Earth Orbiter

FRR – Flight Readiness Review (as defined in [RD. 1])

PDR – Preliminary Design Review (as defined in [RD. 1])

RAAN – Right Ascension of the Ascending Node

SC – Spacecraft



SKA – Studenckie Koło Astronautyczne (Students' Space Association)

SSO – Sun-Synchronous Orbit

TBC – To Be Confirmed

TBD – To Be Defined

WUT – Warsaw University of Technology



	PW-Sat2	Preliminary Design Review	
	2016-11-29	Cameras	
	Phase B		

# 1 INTRODUCTION

---

## 1.1 PURPOSE AND SCOPE

During phase B of the PW-Sat2 project, we have changed a bit in satellite's payload. We came back to the idea of two cameras. At the end of phase A the team has abandoned the use of the camera CAM1, working as Earth-pointing camera, because of the lack of strong arguments and financial issues. Later on we started a cooperation with Creotech Instruments company, that proposed their own design of the On-Board Computer and camera working as a star tracker. We were also looking for appropriate camera for CAM2 (a camera for sail observation) but selection of camera that meets all of the preliminary requirements was very difficult. The team was obliged to check all of the possible solutions to find the most advantageous one.

	PW-Sat2	Preliminary Design Review	
	2016-11-29	Cameras	
	Phase B		

## 2 REFERENCES

---

### 2.1 PROJECT DOCUMENTS



**Table 2-1 List of applicable project documents**

Ref.	Title	Code	Version	Date
[PD. 1]	PW-Sat2 – Preliminary Requirements Review – Cameras	PW-Sat2_10_PRR_CAM_EN	1.0.1 EN	2014-07-02
[PD. 2]	PW-Sat2 – Preliminary Design Review - Overview	PW-Sat2_00_PDR_Overview PW-Sat2-B-00.00-PDR-Overview	1.0	2015-05-18 2016-11-28
[PD. 3]				

### 2.2 REFERENCE DOCUMENTS

**Table 2-2 List of applicable reference documents**

Ref.	Title	Version	Date
[RD. 1]	ECSS-M-ST10C – “Space project management.”	Rev.1	2009.03.06
[RD. 2]			

	PW-Sat2	Preliminary Design Review	
	2016-11-29	Cameras	
	Phase B		

## 3 CAMERAS OBJECTIVES

---

### 3.1 TEAM OBJECTIVES



The mission assumes preparing two cameras. CAM1 – camera working as a star tracker, additionally as an Earth camera. CAM2 – camera for sail observation. The cameras are not the main payload, therefore the main requirement is not to hinder other payload and subsystems, especially in mechanical configuration, and they do not have the priority in operation and power consumption. We mainly care about appropriate operation of basic subsystems, and later we will use the cameras as far as possible, to check the computer processing and communication capabilities while using the camera's data.

### 3.2 GENERAL REQUIREMENTS

The design requirements has changed a bit due to the cooperation with Creotech Instruments. The On-Board-Computer design assumes the same electronic interface for both cameras. The OBC will switch the operation between the cameras, disabling the cameras operating in the same time, and simplifying the OBC electronic board.

As a mechanical requirements, we still do not have too much space between the PC-104 electronic stack and the Sail's container. The maximum dimensions for the lens and board of CAM1 are 35mm x 45mm x 35mm; for CAM2: 20mm x 20mm x 25mm. The weight of tow cameras should be less than 100g. The limit for power is 0.5mW.



	PW-Sat2	Preliminary Design Review	
	2016-11-29	Cameras	
	Phase B		

## 4 CAM1 DESIGN

---

CAM1 Star Tracker design and cameras signal interface are the part of the Creotech Instruments involvement in the project, so here we mention only general information about parameters and mechanical aspects connected with satellite's mechanical configuration.

CAM1 Star Tracker main mission is to test the operation as a star sensor, it's algorithms and precision.

### 4.1 CAM1 PROPERTIES

As it was analysed during earlier phases, the CAM1 will be small board camera, with CMOS sensor and fixed lens on the CS mount. The selected sensor and lens are described below.

**Table 4-1 CMOS sensor parameters**

Sensor	MT9T031
Optical format	1/2-inch
Active imager size	6.55mm x 4.92mm 8.19mm (Diagonal)
Active pixels	2048 x 1536
Pixel size	3.2 $\mu$ m x 3.2 $\mu$ m
Color filter array	RGB Bayer pattern
Shutter type	Global reset release (GRR); electronic rolling shutter (ERS)
Maximum data rate/master clock	48 MPS/48 MHz
ADC resolution	10-bit, on-chip
Supply voltage	3.0V–3.6V (3.3V nominal)
Power consumption	244mW (nominal); 1.65 $\mu$ W (standby)
Operating temperature	0°C to 60°C
Packaging	48-pin CLCC

**Table 4-2 Selected lens parameters**

	PW-Sat2	Preliminary Design Review	
	2016-11-29	Cameras	
	Phase B		

Lens	MPL4.0
Focal length	4mm
Format	1/2-inch
Mount	CS mount
F number	F1.8
Iris	fixed
Dimensions	Ø30mm x 17.5mm
Weight	40.2g
FOV	55.5°

## 4.2 MECHANICAL DESIGN

The mounting of the CAM1 is going to be realized with four threaded rods or screws. They will be mounted on the one side to the sensor's PCB, on the other to the satellites X-minus wall. If this will not be enough to pass the shock tests, there is a possibility to prepare an additional mounting to the main electronics' stack or to the Sail's container.

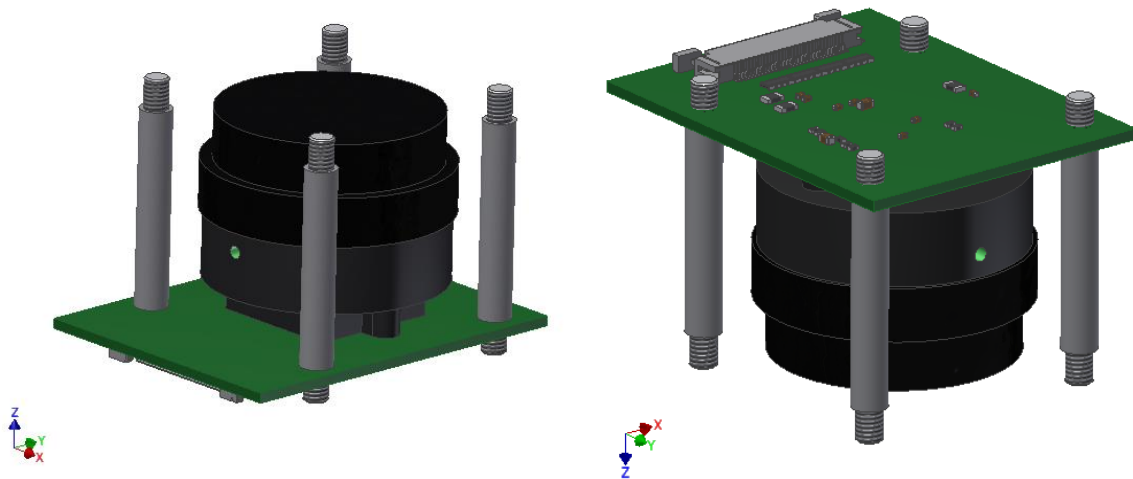



Figure 4-1 CAM1 and mounting elements

	PW-Sat2	Preliminary Design Review	
	2016-11-29	Cameras	
	Phase B		

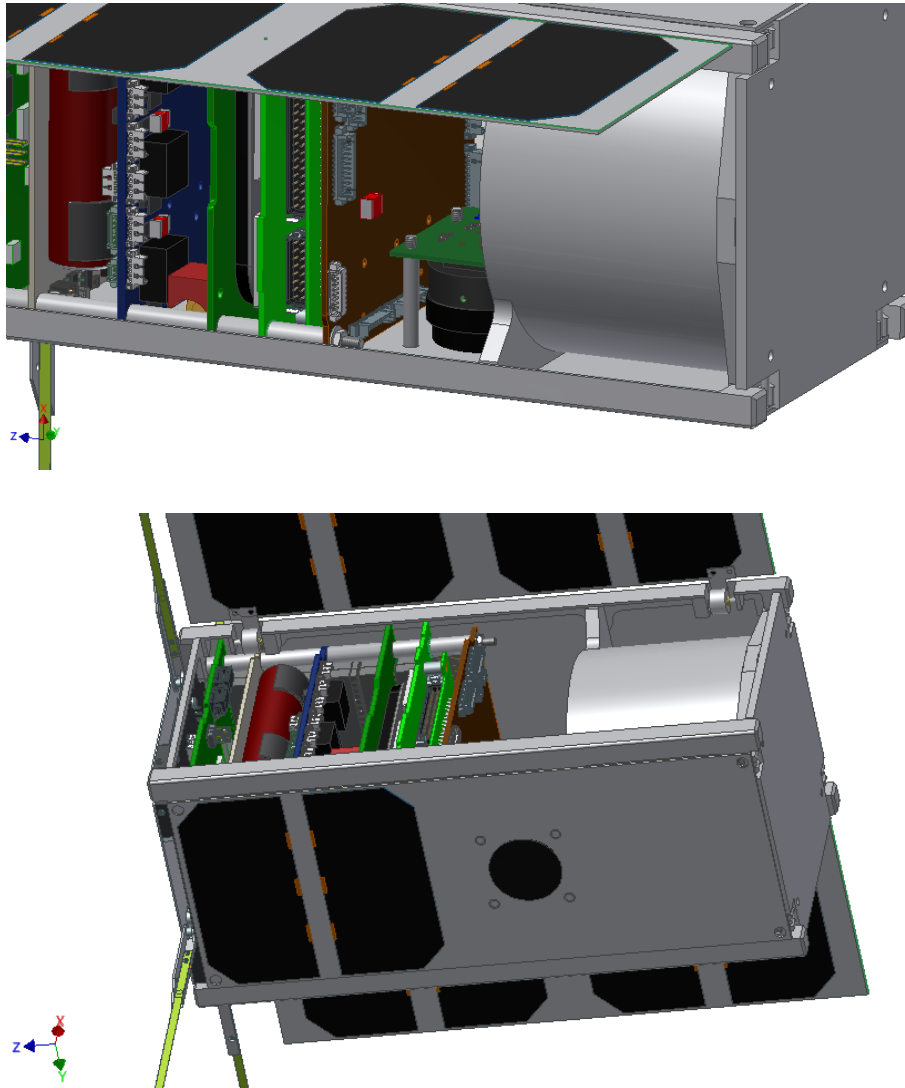



Figure 4-2 CAM1 position on the satellite

### 4.3 CAM1 ON-ORBIT OPERATION

CAM1 will operate on the command from the Ground Station. The On-Board Computer will check what is on the taken photo, and process the image to calculate the satellite's position in reference to the stars in the case of the deep space photo, or treat the image as the Earth photo and prepare the image to be send to the Ground Station during the closest communication session.

	PW-Sat2	Preliminary Design Review	
	2016-11-29	Cameras	
	Phase B		

## 5 CAM2 DESIGN

---

In the phase A there was selected the camera, but because of the cooperation with Creotech Instruments, we decided to choose another one. The main priority was to fit the CAM2 interface to the CAM1 camera. Our requirement of wide field of view,  $\sim 90^\circ$ - $100^\circ$ , was really hard to achieve. The CMOS module cameras are produced with a typical diagonal FOV  $45^\circ$  or  $65^\circ$ . Therefore without the additional optics it is impossible to have a wider field of view.

The mission of the CAM2 is to record a video with the moment of deploying the Sail. This will give us the useful information to verify the Sail design and Sail's deployment mechanism. Additionally CAM2 will take some photos during the deorbit phase to see the Sail during operation.



### 5.1 CAM2 PROPERTIES

There have been made a decision to select the Leopard Imaging LI-OV9712-FF-65 camera, with parameters as below:

**Table 5-1 CMOS module parameters**

Sensor	OmniVision OV9712
Optical format	1/4-inch
Active pixels	1280 x 800
Pixel size	$3\mu\text{m} \times 3\mu\text{m}$
Output format	10-bit RAW RGB
Focal length	3.5mm
Focusing range	60cm to infinity
F number	F2.8
FOV	$65^\circ$ (Diagonal)
Supply voltage	3.0V–3.6V (3.3V nominal)
Power consumption	110mW (nominal); 50 $\mu$ A (standby)
Operating temperature	$-30^\circ\text{C}$ to $70^\circ\text{C}$
Module size	6.5mm x 6.5mm

There are two problems with the selected camera:

	PW-Sat2	Preliminary Design Review	
	2016-11-29	Cameras	
	Phase B		

- The FOV is relatively small;
- The focusing range is out of the smallest distance from Sail to the camera.

The focusing is not the big problem since we will not use the full resolution of the sensor. Due to minimizing the size of the images, normally we are going to use the VGA resolution (640x480) for the video, higher resolution may be used in the photos.

The small field of view of 65° gives the possibility to see the very small part of the Sail (about 1/7). This may be enough, but we want to have better view. Therefore we are analysing the use of the additional lens to have wider field of view, about 90-100°. This will let us to see the 1/4 of the Sail, In the picture below there is showed a comparison between the nominal field of view of the camera, and the widened field of view.

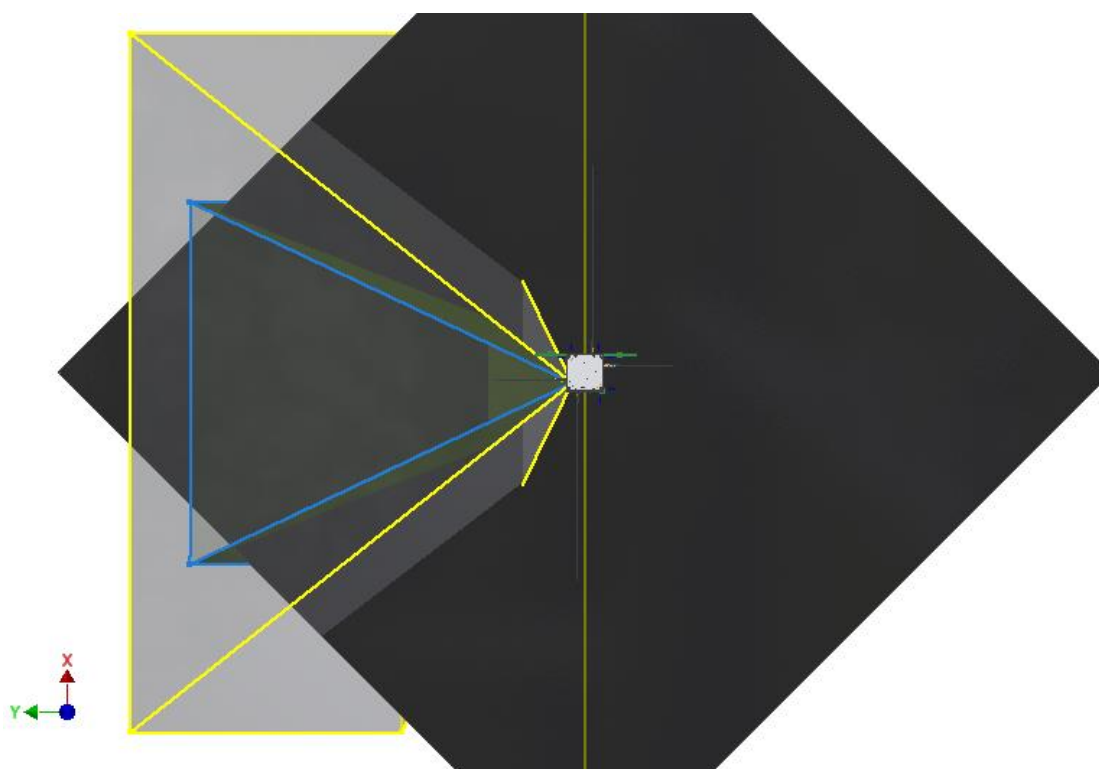



**Figure 5-1 CAM2 field of view: 65° (blue), 95° (yellow)**

The additional lens is during the first design. It may require a two or three lens system, with maximum aperture of 20mm diameter. The lens will be much bigger than the camera module, but it will be still smaller than using bigger camera with wider field of view.

## 5.2 CAM2 MECHANICAL DESIGN

The CMOS module will be built into the mounting. The picture below shows the CAM2 with the additional lens mounted to the electronics' stack with a small metal element.

	PW-Sat2	Preliminary Design Review	
	2016-11-29	Cameras	
	Phase B		

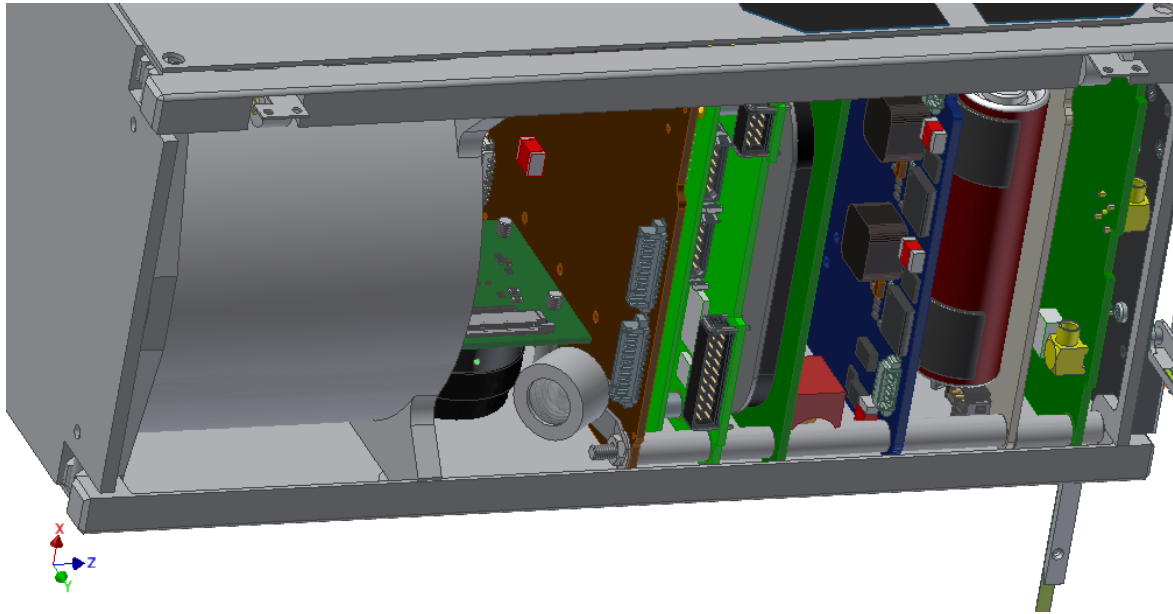



**Figure 5-2 CAM2 mounting**

The CAM2 may be also mounted to the CAM1 PCB board, if the first proposed mounting will be not enough.

### 5.3 CAM2 ON-ORBIT OPERATION

As it was mentioned earlier, the CAM2 will record the video of the Sail deployment. Before this moment, there may be a command from the ground to take a test photo to check the camera's operation or check if the Solar Array has deployed properly. Sail deployment will be recorded in the VGA resolution, with a 4-10 frames per second, in the time of 1-2 minutes. Later there will be photos taken periodically to check the Sail behaviour during deorbit phase.

	PW-Sat2	Preliminary Design Review	
	2016-11-29	Cameras	
	Phase B		

## 6 CONCLUSIONS AND FUTURE WORK

---

During the phase B we have returned to the CAM1 idea because of the cooperation with the Creotech Instruments company. The design of the CAM1 is in the final phase, and in the close future there will be build the first prototype. Also we are going to buy and test the module chosen for the CAM2. The design of the CAM2 additional lens will be prepared and checked in action with the camera. Finally there will be simulated the CAM2 operation with the Sail