

# PW-SAT2

## PRELIMINARY REQUIREMENTS REVIEW

---

### *Sun Sensor*

Phase A of PW-Sat2 project

1.1 EN

pw-sat.pl

**2014-05-08**

#### **Abstract**

The following document is a part of the summary of phase A of the student satellite project PW Sat2. It describes one of the payloads – the Sun Sensor, necessary equipment and a summation of the team's tasks.

The document is published as a part of:



PW-Sat2 – Preliminary Requirements Review

## REVISIONS

Version	Date	Changes	Responsible
0.1		First version of the document.	Inna Uwarowa
1.0 EN	2014-04-07	Editing	Dominik Roszkowski
1.0.1 EN	2014-07-02	Small editorial changes	Dominik Roszkowski
1.1 EN	2017-03-21	Disclaimer added – out of date doc	Dominik Roszkowski

**Attention** Phase A documentation may be outdated in many points. Please do not depend on Phase B or Phase A documents only. Current documentation is available on the project website [pw-sat.pl](http://pw-sat.pl)

This document is also available in Polish.

	PW-Sat2	Sun Sensor	
	1.1 EN	pw-sat.pl	
	Phase A of PW-Sat2 project		

## TABLE OF CONTENTS



<b>1</b>	<b>A description of the Sun Sensor (Sun Sensor)</b>	<b>3</b>
1.1	<i>The aim</i>	3
1.2	<i>Mechanical properties</i>	3
1.3	<i>Price</i>	4
<b>2</b>	<b>SunS success levels</b>	<b>5</b>
<b>3</b>	<b>SunS team tasks</b>	<b>8</b>
3.1	<i>Sun Simulator</i>	8
3.2	<i>Test stand structure</i>	9
3.3	<i>Sun Sensor case</i>	10
3.4	<i>Thermal analyses</i>	11
<b>4</b>	<b>Future work</b>	<b>12</b>
<b>5</b>	<b>Attachments</b>	<b>13</b>

## LIST OF FIGURES

Figure 1-1	Model of the Sun Sensor	4
Figure 2-1	ISIS reference sun sensor	5
Figure 3-1	"Słonecznik" Sun simulator	8
Figure 3-2	Sun Simulator mounting structure	9
Figure 3-3	Sun Sensor test stand	9
Figure 3-4	Sun sensor case	10
Figure 3-5	Thermal analysis results for Sun Sensor case	11

## LIST OF TABLES

Table 2-1	Sun Sensor success levels	7
Table 4-1	Estimated time necessary to finish selected tasks	12

	PW-Sat2	Sun Sensor	
	1.1 EN	pw-sat.pl	
	Phase A of PW-Sat2 project		

# 1 A DESCRIPTION OF THE SUN SENSOR (SUN SENSOR)

## 1.1 THE AIM

The main mission of our team is to create Sun Sensor (hereinafter referred to as Sun Sensor or SunS) as a payload for PW-Sat2 satellite. The Sun Sensor is a new version of an analogue two-axis device which was a bachelor thesis of one of our students in 2008, so the idea to test this device on PW-Sat2 satellite came later in 2011.

Detailed description of the subsystem can be found in the attachment 1<sup>1</sup>. This document will present only general view on a project.

The analogue sun sensor is the second priority payload on PW-Sat2 satellite.

## 1.2 MECHANICAL PROPERTIES

The main advantage of this device is that its mechanical structure is very simple. It can be mounted on the side of one unit CubeSat wall. There are no moving mechanical or complicated parts. [Figure 1-1]

---

<sup>1</sup> Uwarowa Inna, *Ocena dokładności wyznaczania pozycji satelity przy użyciu różnych czujników słonecznych*, engineer's work, Warsaw University of Technology, Warsaw 2011.

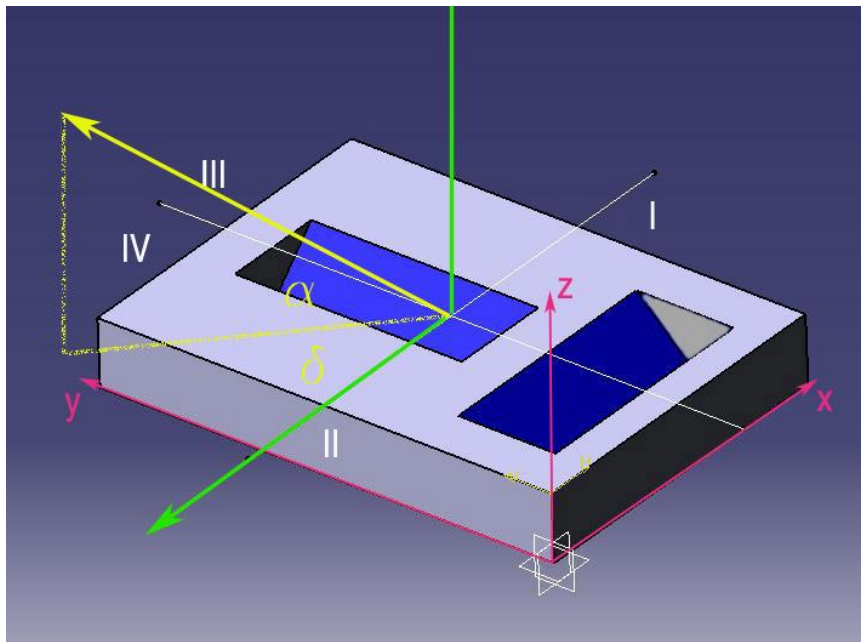



Figure 1-1 Model of the Sun Sensor

### 1.3 PRICE

The sun sensor device is assembled from cheap and easily available materials. The light sensible material is a simple photovoltaic cell. It is not necessary to use high efficiency cell because the energy obtained is not the goal.

	PW-Sat2	Sun Sensor	
	1.1 EN	pw-sat.pl	
	Phase A of PW-Sat2 project		

## 2 SUNS SUCCESS LEVELS

The main goal of this payload is to test the sun sensor device on orbit. The assumed theoretical accuracy is  $0.1^\circ$ , which is hard to obtain in real device. The mission is to check if the Sun Sensor achieves the assuming accuracy comparable to reference ADCS sensor device.

There were defined 4 success levels for the sun sensor device described below.

As the reference Sun sensor two types of devices can be used:

1. Magnetometers – the accuracy is determined at  $3^\circ$ . The sensors have relatively low accuracy in comparison to other devices. The sun sensor will have certainly three times higher accuracy. However due to the finances constraints the magnetometers are the basic option to check the sun sensor accuracy.
2. Sun Sensor – reference Sun sensor delivered by ISIS [Figure 2-1], defined accuracy is  $0,5^\circ$ . It will verify and prove higher accuracy of the Sun Sensor.



Figure 2-1 ISIS reference sun sensor



The reference Sun sensor technical data is presented below.

### Performance

- Field of view:  $114^\circ$
- Update Rate:  $>10$  Hz (limited by ADC)
- Accuracy:  $<0.5^\circ$
- Interfaces:
  - Power Supply: 5V
  - I/F: 5 analogue channels, 9-way Nano-D connector

### Product Properties



- Mass:  $< 5$  g
- Power:  $< 10$  mA
- Size: 33mm x 11mm x 6mm
- Environmental Characteristics
  - Operating temperature:  $-25^\circ\text{C}$  to  $+50^\circ\text{C}$
  - 250 rms random, 1000g shock (Qualification levels)
  - 10krad total dose (component level)

	PW-Sat2	Sun Sensor	
	1.1 EN	pw-sat.pl	
	Phase A of PW-Sat2 project		

There were defined 4 success levels for the Sun Sensor device which are described below. Following example shows the comparison with magnetometers as the reference sensor.

Table 2-1 shows Sun Sensor success levels and the requirements for the other subsystems, which must be followed for each success level.



1. The first and the highest success level means that the sun sensor indications will be equal to the data produced by magnetometer with deviation of  $\pm 3^\circ$  ( $\sigma$ ). This success level assumes also full angles verification. This means greater involvement from ADCS and EPS.
2. The second success level is to compare the sun sensor indications with magnetometers with the same deviation but in the limited field of view. In this case we cannot use ADCS for full angles verification movement. However, we can compare the indications with magnetometers and photodiodes.
3. In the third case we assume no possibility to compare the indications with neither magnetometers nor with photodiodes. Knowing the accuracy obtained during the tests we can compare the indications on orbit.
4. The last and the lowest success level are Sun Sensor ground tests. Since the obtained accuracy ( $0.5^\circ$ ) will provide 20% of theoretical accuracy ( $0.1^\circ$ ), this will be considered as fourth level success.

	PW-Sat2	Sun Sensor	
	1.1 EN	pw-sat.pl	
	Phase A of PW-Sat2 project		

Payload	Success level	Description	EPS	OBC	ADCS	Comm UHF/VHF	Antenna UHF/VHF	TCS	Structure	SADS	Sail
SunS	1	accuracy SunS = accuracy Mgtm	3,2Wh = com 2W/min + SunS 1W/20min +OBC 1,5W/0,5h+ ADCS 2W	10kB	on - full control for every range of angles	on 1min	on	-	-	-	-
	2	accuracy SunS = accuracy Mgtm	2,2Wh = com 2W/min + SunS 1W/20min +OBC 1,5W/0,5h+ADCS 1W	10kB	only mgtmeter and diodes	on 1min	on	-	-	-	-
	3	accuracy SunS = accuracy Mgtm	1,2Wh = com 2W/min + SunS 1W/20min +OBC 1,5W/0,5h	10kB	-	on 1min	on	-	-	-	-
	4	accuracy SunS = theoretical accuracy	-	-	-	-	-	-	-	-	-

Table 2-1 Sun Sensor success levels



	PW-Sat2	Sun Sensor	
	1.1 EN	pw-sat.pl	
	Phase A of PW-Sat2 project		

### 3 SUNS TEAM TASKS

To realize this idea we have to create a special test stand for Sun Sensor tests. Test stand organization can be divided into few main tasks:

#### 3.1 SUN SIMULATOR

Fortunately, we didn't have to create a new sun simulator. One of the previous projects of Students' Space Association was a special sun simulator dedicated to ESEO mission [See Attachment<sup>2</sup>]. Unfortunately the project was not completed, so we had to turn it on again and adapt it for our test stand.

First initiation took place in Space Research Center (Polish Academy of Science) in July during internships of three of our SunS team members. We have managed to turn it on and made temperature measurements.

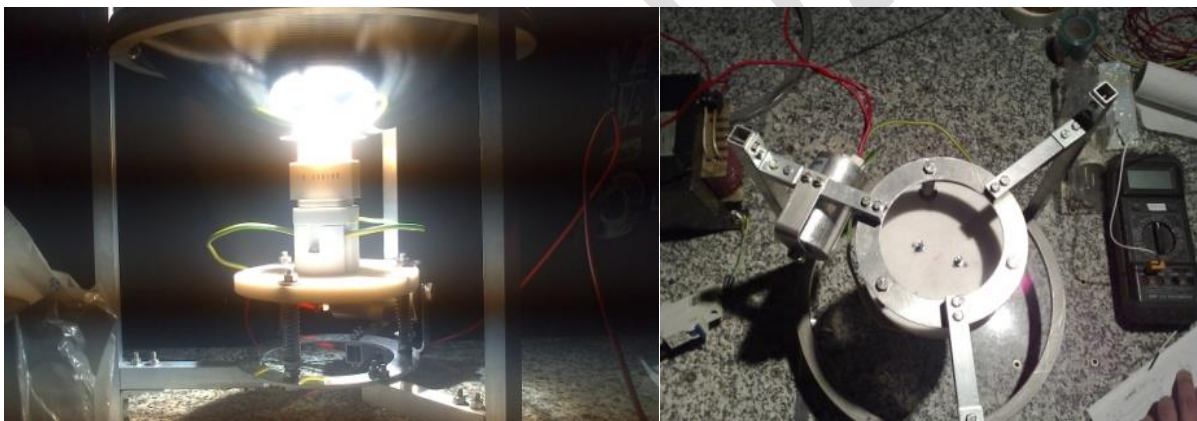

**Figure 3-1 "Słonecznik" Sun simulator**

To make it completely usable for our needs we still have to build a special stand to hold "Słonecznik" in the position of horizontal "Sun" rays. [Figure 3-2]

---

<sup>2</sup> Furła P., Kwas M., Toruniewska J., *SŁONECZNIK Symulator Słońca do Komory Próżniowej*, Studenckie Koło Astronautyczne, Politechnika Warszawska, Warszawa 2012.



	PW-Sat2	Sun Sensor	
	1.1 EN	pw-sat.pl	
	Phase A of PW-Sat2 project		



Figure 3-2 Sun Simulator mounting structure

### 3.2 TEST STAND STRUCTURE

The test stand structure project was created during already mentioned internship in SRC in July. The project was approved and in a few next months the parts were ordered. The delay was caused because of holiday's period, where people responsible for finances were absent. The test stand structure was a bachelor thesis<sup>3</sup> of one of SunS team members, who had his defence in January/February 2014.

#### THE TEST STAND STRUCTURE HAD TO MEET FOLLOWING CONDITIONS:

1. Providing the motion up to 90° in two axes.

To follow this condition a special design was created.

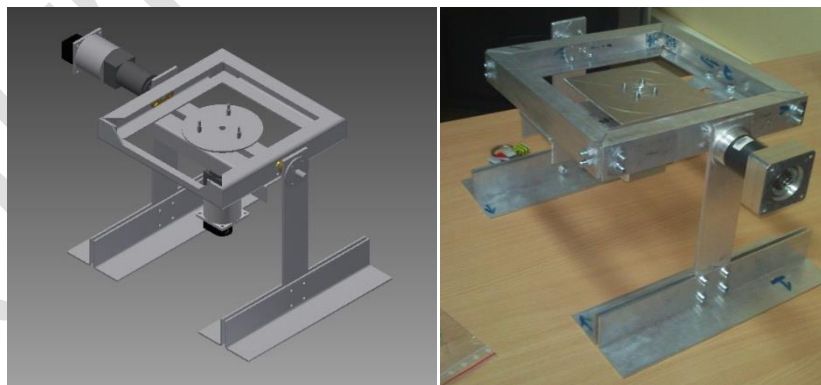



Figure 3-3 Sun Sensor test stand

---

<sup>3</sup> Łukasik Artur, *Konstrukcja stanowiska do testowania czujnika położenia satelity w przestrzeni kosmicznej*, engineer's work, Warsaw University of Technology, Warsaw 2014.

	PW-Sat2	Sun Sensor	
	1.1 EN	pw-sat.pl	
	Phase A of PW-Sat2 project		

- The step for each angle change had to be lower than  $0,1^\circ$

To follow this condition we ordered a set of stepper motors with gears and.

- Two angles range must be from  $-90^\circ$  to  $+90^\circ$ .

The structure can be assembled and disassembled. The main reason to not assemble it finally now is that we would like to test the Sun Sensor in a dark room where we can change the distance between the sun simulator and sun sensor stand. These conditions are available in SRC, so we will have only few days for transporting it and testing. Now all the parts are in the Institute of Heating at Warsaw University of Technology.

### 3.3 SUN SENSOR CASE

Sun Sensor case for mounting solar cells was designed. The main question was whether the case will deform and affect the solar cells mounting angle after the heat changes. The thermal calculation has been done in Asatan. The program did not show any significant deformations [Figure 3-5]

The case has been produced in January 2014 [**Błąd! Nie można odnaleźć źródła odwołania.**].

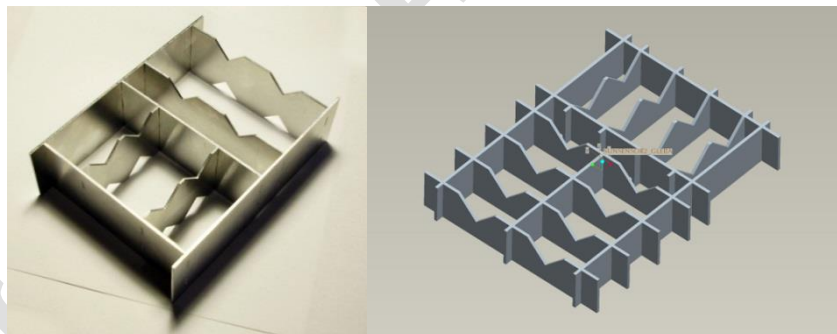

Figure 3-4 Sun sensor case

Sun sensor board and stand electronics and software is one the tasks of E&S Team. Their report describes the progress of this work.

### 3.4 THERMAL ANALYSES

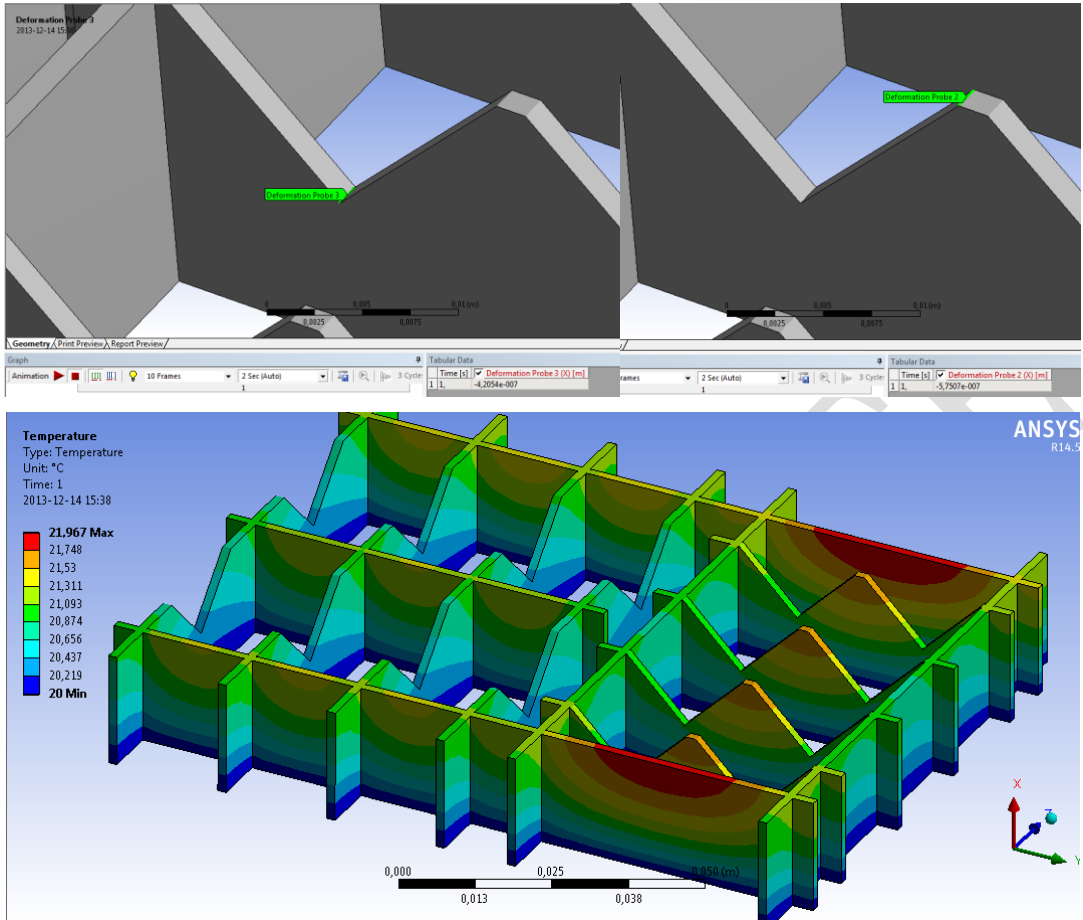



Figure 3-5 Thermal analysis results for Sun Sensor case

	PW-Sat2	Sun Sensor	
	1.1 EN	pw-sat.pl	
	Phase A of PW-Sat2 project		



## 4 FUTURE WORK

Phase B assume full tests of the sun sensor device. The first version of solar cells is only for preliminary tests.

Next version of the solar cells was chosen.

Part	Task	Manpower
Solar simulator	Stability problems (stabilizer)	12h
Test stand mechanics	Spring	1h
	Tests	4h
Test stand electronics	Development	2h
Sun sensor case-flight version	Design	10h
	Material choosing	5h
	Manufacturing	2 weeks
Sun sensor electronics and software	Developing	20h
	Design	5h
	Manufacturing	2 weeks
Tests	Preliminary	40h
	Final	40h
Total		140h + 4 weeks

Table 4-1 Estimated time necessary to finish selected tasks

	PW-Sat2	Sun Sensor	
	1.1 EN	pw-sat.pl	
	Phase A of PW-Sat2 project		

## 5 ATTACHMENTS

[1] Uwarowa Inna, *Ocena dokładności wyznaczania pozycji satelity przy użyciu różnych czujników słonecznych*, engineer's work, Warsaw University of Technology, Warsaw 2011.

[PW-Sat2\_09\_PRR\_SunS\_IUwarowa\_Praca\_inz\_SunS.pdf]

[2] Furła P., Kwas M., Toruniewska J., *SŁONECZNIK Symulator Słońca do Komory Próżniowej*, Students' Space Association, Warsaw University of Technology, Warsaw 2012.

[PW-Sat2\_09\_PRR\_SunS\_Symulator\_Slonca\_Sprawozdanie\_SKA.pdf]

[3] Łukasik Artur, *Konstrukcja stanowiska do testowania czujnika położenia satelity w przestrzeni kosmicznej*, engineer's work, Warsaw University of Technology, Warsaw 2014.

[PW-Sat2\_09\_PRR\_Suns\_ALukasik\_Praca\_Inz\_Slonecznik.pdf]